

# mesoS-10

THIS DRAWING AND ALL DATA INCLUDED IS THE PROPERTY OF APPLIED SCIENTIFIC INSTRUMENTATION AND THE INFORMATION CONTAINED HEREIN IS FOR GENERAL PRESENTATION PURPOSES ONLY AND MAY CHANGE AT ANY TIME. CONTACT ASI OR A FACTORY REPRESENTATIVE FOR PROJECT SPECIFIC ENGINEERING.

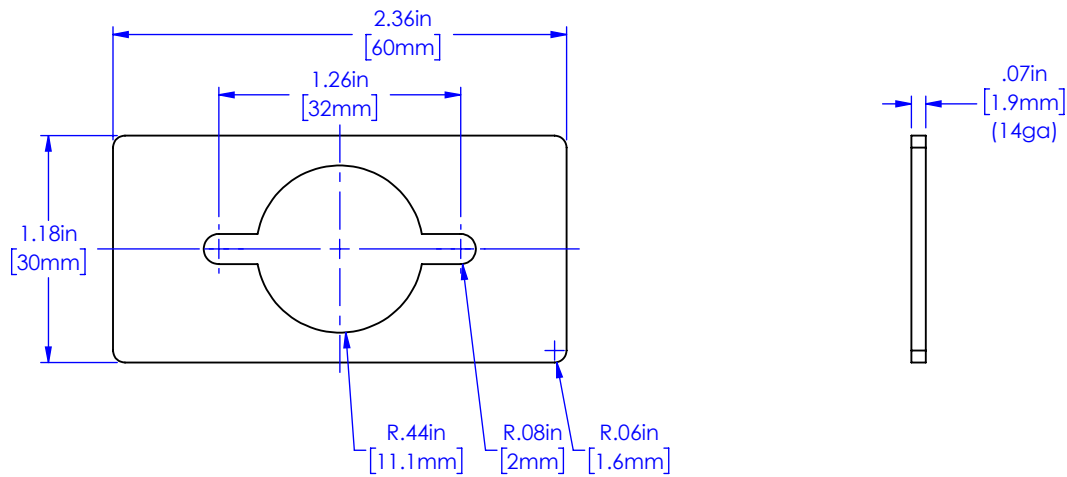
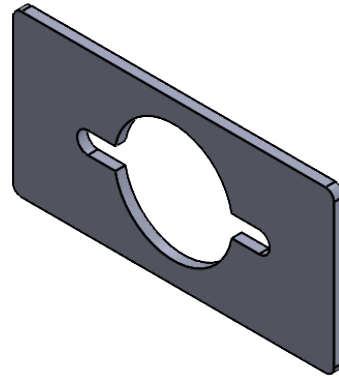

**PROPRIETARY AND CONFIDENTIAL**  
THE INFORMATION CONTAINED IN THIS DRAWING IS THE SOLE PROPERTY OF APPLIED SCIENTIFIC INSTRUMENTATION. ANY REPRODUCTION IN PART OR AS A WHOLE WITHOUT THE WRITTEN PERMISSION OF APPLIED SCIENTIFIC INSTRUMENTATION IS PROHIBITED.

APPLIED SCIENTIFIC INSTRUMENTATION  
29391 W ENID RD  
EUGENE, OR 97402-9533  
PHONE: (541)461-8181  
FAX: (541)461-4018

UNLESS OTHERWISE SPECIFIED  
DIMENSIONS ARE IN INCHES  
.xx ± .01  
.xxx ± .005  
.xxxx ± .0002  
FRACTIONS ± 1/32  
ANGLES ± 1°

**DESCRIPTION**  
**mesoS-10 2mm HEAT SINK**  
**(normally qty 7 required per side)**

DRAWN BY/DATE

M.ANTHONY 11/13/23

CHECKED BY/DATE

V.MARSO 11/13/23

SCALE

1:1

REV

-

MATERIAL

14ga ALUM

DRAWING #

mesoS-10